

MEGA^{LITE}

Tiltbot TRIO



USER MANUAL

Table of Contents

Safety Information	3
Specifications	4
Main Power Connection	5
DMX-512 Connection	5
Size and Weight	6
Main Control Menu	7
DMX Profile	9
Parts List	8
Rigging the Fixture	12
Cleaning & Maintenance	13

Check that the unit has not been damaged during transport



Read all cautions and warnings
prior to operation of this
equipment

Protection Against Fire



1. Maintain a minimum of 1 foot distance from any type of flame.
3. Replace fuse only with the specified type and rating.
4. Do Not install the unit too close to a heat source.
5. Make sure cables are properly secured
6. Maximum surface operating temperature 140°.

Protection Against Electrical Fire

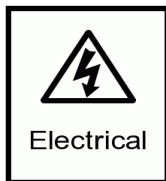

1. Disconnect power before servicing.
2. For connection to main power supply proceed to page 6.
3. This unit must be earthed. (electronically grounded)
4. This fixture must not be left on for long periods of time.

Protection Against Mechanical Hazards



1. Use safety chain when hanging unit.
2. Use quality clamps or bolts when positioning unit
3. Do not open unit while it is on, risk of electrical shock.

Ingress Protection



The IP rating is commonly expressed as **IP (Ingress Protection)** is followed by 2 numbers (i.e. 65) where the numbers define the fixture rating. The first number indicates the size of a particle that can enter the fixture.. The second number indicates the extent of protection against water entering the fixture. An IP65 rating in this fixture indicates that dust particles can not enter the fixture. And there is protection against powerful water spray from entering the fixture from any direction.

Technical Information

Part Numbers

Fixture

1310-Tiltbot Trio

Road Case

CAS-1310-4 4 Unit Road Case

Mechanical Specifications

DMX Connectors:	Panel Mounted IP67 5-pin XLR connectors in/out
Power Connections:	Panel Mounted Seetronic IP Rated Power in/out connection (Nema 5-15 to Seetronic power Female cable included)
Thermal:	Maximum ambient temperature 40° C Maximum surface temperature 60° C
Display:	Digital
Fastening System:	2 Quick Release Clamp Mount
Lens Angle:	N/A°
Ip Rating:	IP64

Electrical Specifications

LED Type:	572 RGB 1W and 144 White 8W
CRI:	90 on White
LED Lifetime:	50,000 to 80,000 hours (Average)
Power Consumption:	Universal 100 - 240V 50/60 Hz
Ballast:	Electronic
Watts:	713W
Amps:	6.22A
PF:	.99

Control & Programming

Protocol:	DMX 512
RDM:	Yes
DMX Channels:	6 Mode of Operation Mode 3 Ch: Tilt, Fine Tilt, Strobe Mode 12 Ch: Tilt, Fine Tilt, Dimmer, RGB Intensity, Red, Green, Blue, Duration RGB, Strobe RGB, White, Duration White, Strobe White Mode 14 Ch: Tilt, Fine Tilt, Dimmer, Red, Green, Blue, Macro, Macro Speed, RGB Strobe, White, Macro, Macro Speed, White Strobe, White Dim Mode 23 Ch: Tilt, Fine Tilt, White, W Duration, W Strobe, Macro, Control, RGB intensity, RGB Duration, RGB Strobe, Macro, Red, Green, Blue, FX Fade, Color FX, Color Select, White FX, White Select, Color Back, Intensity, Red back, Green Back, Blue Back Mode 50 Ch: Tilt, Fine Tilt, RGB X 12, White X 12 Mode 62 Ch: Tilt, Fine Tilt, Dimmer, Red, Green, Blue, Macro, Macro Speed, RGB Strobe, White, Macro, Macro Speed, White Strobe, White Dim, RGB X 12, White X 12
Operating Mode:	Stand alone 255 step dimmer setting via display Auto preprogram via display



Main Power Connection

Caution!

1. Do not connect fixture to a dimmer system.
2. This unit has Auto switching power supply. It will respond to 110V or 240V automatically
3. This unit must be earthed. (electronically grounded)
4. Replace fuse only with the specified type and rating.
5. Power Link 2 units at 110V and 4 units at 220V

The occupation of the connection-cable is as follows:

This fixture is equipped with an electronic power supply that will let the unit operate from 100V to 240V from 50Hz to 60Hz

Cable (USA)	Cable (EU)	Pin	110V	220V
Black	Brown	Live	L	L
White	Light Blue	Neutral	N	L
Green	Yellow/Green	Ground		

110V—Connection

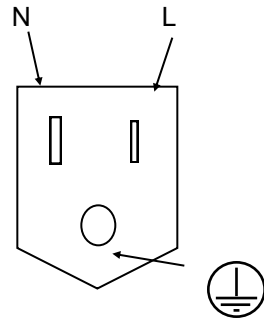

220V—Connection

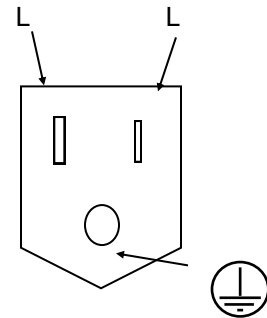

DMX-512 Connection

The fixture is equipped with 5 pin XLR cable mounted sockets for DMX input and output. The sockets are wired in parallel. Only use a shielded twisted pair cable designed for RS-485 and 5 pin XLR plugs and connectors in order to connect the controller with the fixture or the fixture with another.

DMX—input

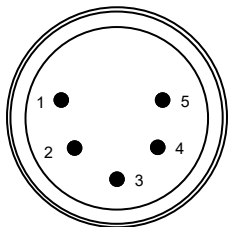

1. Shield
2. Signal (-)
3. Signal (+)
4. N/A
5. N/A

DMX—output

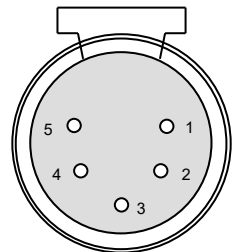

Caution!

At the last fixture the DMX signal needs to be terminated with a terminator. Solder a 120 Ohm resistor between the (-) and the (+) signal into a 5 pin XLR plug and plug it in to the last fixture on the signal run. Pre-manufactured terminator plugs are available for purchase from your Mega-Lite dealer (P-DMXT).

Size and Weight

Size	22.12" X 13.12" X 5.5"
Weight	23lb
Packaged	27.36" X 9" X 17.25" 25lb

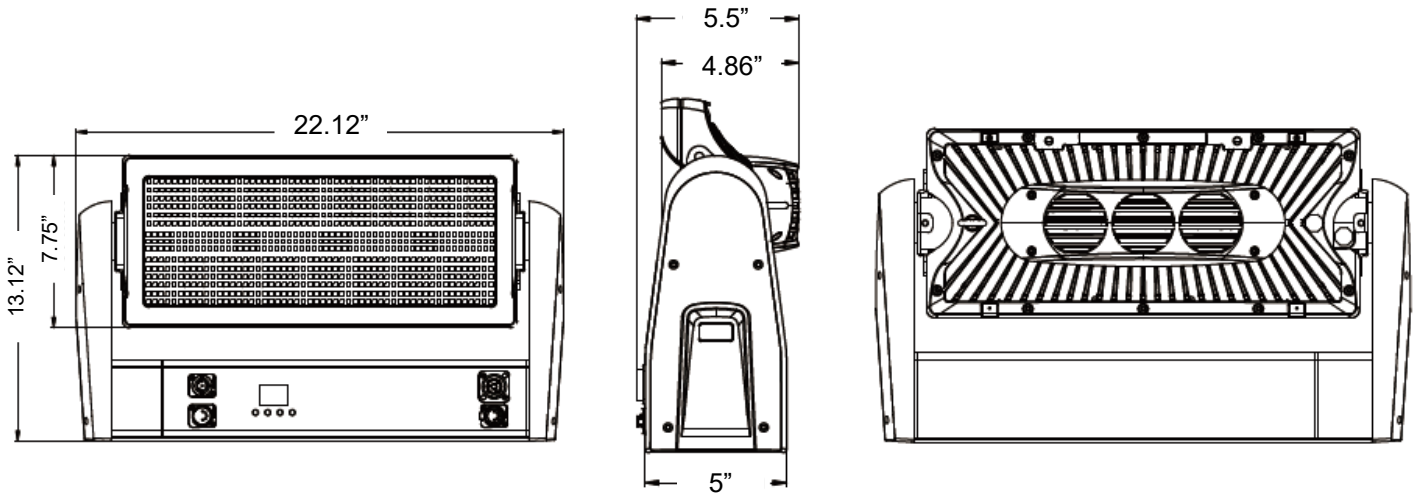

7"

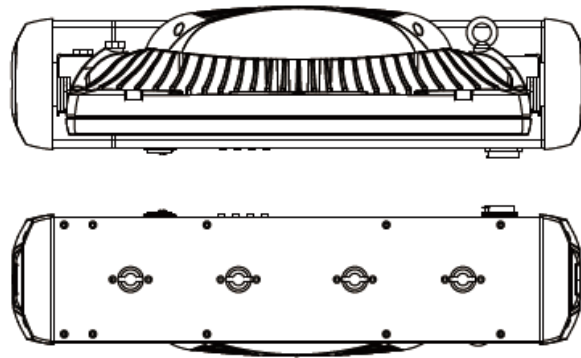

Main Control Menu

The control board on the fixture is your interface to access and control all the functions on the unit. Its digital display gives you a code view of the options and functions. The following will explain each function and its options.

CONTROL BOARD

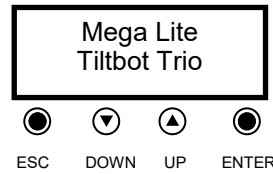

Address 001 DMX On	<h3>DMX Address</h3> <p>Press Enter to select the DMX start channel. Use the up/down keys (001 to 512) , Press Enter to confirm the setting. Press ESC to return to Main Menu.</p> <p>(Notes: Display must be on Main Menu for fixture to operate on DMX Mode)</p>
------------------------------	--

Main Menu > Channel Mode Led Dimmer Strobe Mode	<h3>Channel Mode</h3> <p>Press Enter to select the DMX Channel mode of operation. Use the up/down keys to select Channel mode from. Press Enter to confirm the setting. Press ESC to return to Main Menu</p> <table border="1" style="width: 100%; border-collapse: collapse;"> <tr> <td style="width: 10%;">3 CH</td> <td>Tilt, Fine Tilt, Strobe</td> </tr> <tr> <td>12 CH</td> <td>Tilt, Fine Tilt, Dimmer, RGB Intensity, Red, Green, Blue, Duration RGB, Strobe RGB, White, Duration White, Strobe White</td> </tr> <tr> <td>14 CH</td> <td>Tilt , Fine Tilt, Dimmer, Red, Green, Blue, Macro, Macro Speed, RGB Strobe, White, Macro, Macro Speed, White Strobe, White Dim</td> </tr> <tr> <td>23 CH</td> <td>Tilt, Fine Tilt, White, W Duration, W Strobe, Macro, Control, RGB intensity, RGB Duration, RGB Strobe, Macro, Red, Green, Blue, FX Fade, Color FX, Color Select, White FX, White Select, Color Back Intensity, Red back, Green Back, Blue Back</td> </tr> <tr> <td>50 CH</td> <td>Tilt, Fine Tilt, RGB X 12, White X 12</td> </tr> <tr> <td>62 CH</td> <td>Tilt , Fine Tilt, Dimmer, Red, Green, Blue, Macro, Macro Speed, RGB Strobe, White, Macro, Macro Speed, White Strobe, White Dim, RGB X 12, White X 12</td> </tr> </table>	3 CH	Tilt, Fine Tilt, Strobe	12 CH	Tilt, Fine Tilt, Dimmer, RGB Intensity, Red, Green, Blue, Duration RGB, Strobe RGB, White, Duration White, Strobe White	14 CH	Tilt , Fine Tilt, Dimmer, Red, Green, Blue, Macro, Macro Speed, RGB Strobe, White, Macro, Macro Speed, White Strobe, White Dim	23 CH	Tilt, Fine Tilt, White, W Duration, W Strobe, Macro, Control, RGB intensity, RGB Duration, RGB Strobe, Macro, Red, Green, Blue, FX Fade, Color FX, Color Select, White FX, White Select, Color Back Intensity, Red back, Green Back, Blue Back	50 CH	Tilt, Fine Tilt, RGB X 12, White X 12	62 CH	Tilt , Fine Tilt, Dimmer, Red, Green, Blue, Macro, Macro Speed, RGB Strobe, White, Macro, Macro Speed, White Strobe, White Dim, RGB X 12, White X 12
3 CH	Tilt, Fine Tilt, Strobe												
12 CH	Tilt, Fine Tilt, Dimmer, RGB Intensity, Red, Green, Blue, Duration RGB, Strobe RGB, White, Duration White, Strobe White												
14 CH	Tilt , Fine Tilt, Dimmer, Red, Green, Blue, Macro, Macro Speed, RGB Strobe, White, Macro, Macro Speed, White Strobe, White Dim												
23 CH	Tilt, Fine Tilt, White, W Duration, W Strobe, Macro, Control, RGB intensity, RGB Duration, RGB Strobe, Macro, Red, Green, Blue, FX Fade, Color FX, Color Select, White FX, White Select, Color Back Intensity, Red back, Green Back, Blue Back												
50 CH	Tilt, Fine Tilt, RGB X 12, White X 12												
62 CH	Tilt , Fine Tilt, Dimmer, Red, Green, Blue, Macro, Macro Speed, RGB Strobe, White, Macro, Macro Speed, White Strobe, White Dim, RGB X 12, White X 12												

Main Menu Channel Mode > Led Dimmer Strobe Mode	<h3>LED Dimmer</h3> <p>For LED Dimmer control press Enter. Select from 255 steps. Of the 50 ch. Press ESC to return to Main Menu.</p>
---	---

Main Menu Channel Mode Led Dimmer > Strobe Mode	<h3>Strobe Mode</h3> <p>This function allows you to select a preprogrammed strobe sequences. Press Enter use the up/down keys to select desired strobe program (15 options). Press Enter to set the desired sped use the up/down keys (15 options). Press Enter to confirm the settings. (note; Dimmer of selected intensity must be dimmed prior in Dimmer option)</p>
---	--

Main Menu > Auto Mode Auto Speed Fan Test	<h3>Auto Mode</h3> <p>Press Enter. Select from 6 modes Press ESC to return to Main Menu.</p> <p>(Note: If you want to have fixture remain on Auto Test do not press ESC and just power off and on fixture to return to last setting)</p>
---	--

Main Menu Auto Mode >Auto Speed Fan Test	<h3 style="margin: 0;">Auto Speed</h3> <p style="margin: 5px 0;">Press Enter. Select from 6 modes Press ESC to return to Main Menu.</p> <p style="margin: 5px 0;">(Note: If you want to have fixture remain on Auto Test do not press ESC and just power off and on fixture to return to last setting)</p>
---	--

Main Menu Auto Mode Auto Speed >Fan Test	<h3 style="margin: 0;">Temperature</h3> <p style="margin: 5px 0;">This fixture is equipped with internal temperature sensors. Once head reaches a temperature of 96°the IP rated fan will engage</p>
---	--

Main Menu Temperature >Setting	<h3 style="margin: 0;">Setting</h3> <p style="margin: 5px 0;">Setting Control Options</p>
--	---

Config Menu
>LCD Back Light
 DMX Fail
 RDM

To turn off LCD Screen after 2 minutes of no use select **Disable**. To enable screen to remain on when in use select **Enable**.

Config Menu
 LCD Back Light
> DMX Fail
 RDM

To hold the last DMX command in case of DMX Signal loss select **Enable**. To have the fixture DMX Setting at 0 if DMX signal is loss use **Disable** option.

Config Menu
 LCD Back Light
 DMX Fail
> RDM

RDM Status	You can Enable or Disable the RDM feature
RDM UID	6342774B9875
RDM ID	0001

Config Menu
>Fan Speed
 Dimmer Setting
 Factory Reset

Fan Speed Option include
 Standard=
 Low=
 High=

Config Menu
 Fan Speed
> Dimmer Setting
 Factory Rese

Select Dimmer Setting to be used for dimming type when used in Ch13 / 62mode.
 Applies only to White LED's
 Linear
 Square Law

Config Menu
 Fan Speed
 Dimmer Setting
>Factory Reset

Restore fixture to original factory display settings

DMX Profile

Tiltbot Trio 3 Ch Mode

DMX Channel	Function	Description	Value	Init
1	Tilt	Tilt	0-255	127
2	Tilt Fine	Tilt Fine	0-255	127
3	Strobe	No Function	0-10	0
		Strobe (slow to fast)	11-255	

Tiltbot Trio 12 Ch Mode

DMX Channel	Function	Description	Value	Init
1	Tilt	Tilt	0-255	127
2	Tilt Fine	Tilt Fine	0-255	127
3	Dimmer	Dimmer (off to full)	0-255	255
4	RGB Intensity	RGB Intensity	0-255	255
5	LED Color	Red LED Intensity	0-255	255
6	LED Color	Green LED Intensity	0-255	255
7	LED Color	Blue LED Intensity	0-255	255
8	Duration	Duration RGB	0-255	255
9	Strobe	Strobe RGB	0-255	255
10	LED Color	White LED Intensity	0-255	255
11	Duration	Duration White	0-255	255
12	Strobe	Strobe White	0-255	255

Tiltbot Trio 14 Ch Mode

DMX Channel	Function	Description	Value	Init
1	Tilt	Tilt	0-255	127
2	Tilt Fine	Tilt Fine	0-255	127
3	Dimmer	Dimmer (off to full)	0-255	255
4	LED Color	Red LED Intensity	0-255	255
5	LED Color	Green LED Intensity	0-255	255
6	LED Color	Blue LED Intensity	0-255	255
7	RGB Macro (Select Color)	No Function	0-1	0
		Fade 1,2,3,4,5,6,12,11,10,9,8,7	2-17	
		Fade 12,11,10,9,8,7,1,2,3,4,5,6	18-35	
		Snap 1,2,3,4,5,6,12,11,10,9,8,7	36-53	
		Snap 12,11,10,9,8,7,1,2,3,4,5,6	54-71	
		Fade 1+2+3+4+5+6 then 7+8+9+10+11+12	72-89	
		Snap 1+2+3+4+5+6 then 7+8+9+10+11+12	90-107	
		Bounce 1+7,2+8,3+9,4+10,5+11,6+12	108-125	
		Bounce 6+12, 5+11,4+10,3+9,2+8,1+7	126-143	
		Fade 1+7,2+8,3+9,4+10,5+11,6+12	144-161	
		Fade 3+4+9+10, 2+8+5+11,1+7+6+12	162-179	
		Snap 1+12,2+11,3+10,4+9,5+8,6+7	180-197	
		Bounce 1+12,2+11,3+10,4+9,5+8,6+7	198-215	
		Snap 3+10, 4+9, 2+11, 5+8,1+12, 6+7	216-233	
Fade Random	234-244			
Snap Random	245-255			
8	Macro Speed	Macro Speed	0-255	0
9	RGB Strobe	No Function	0-1	0
		Strobe (slow to fast)	2-127	
		Strobe Pulse (slow to fast)	128-170	
		Random Strobe All (slow to fast)	171-213	
10	LED Color	Random 1-12 Strobe (slow to fast)	214-255	255
		White LED Intensity	0-255	
11	White Macro (Select Intensity)	No Function	0-1	0
		Fade 1,2,3,4,5,6,7,8,9,10,11,12	2-17	
		Fade 12,11,10,9,8,7,6,5,4,3,2,1	18-35	
		Snap 1,2,3,4,5,6,7,8,9,10,11,12	36-53	
		Snap 12,11,10,9,8,7,6,5,4,3,2,1	54-71	
		Fade 1+2+3+4+5+6 then 7+8+9+10+11+12	72-89	
		Snap 1+2+3+4+5+6 then 7+8+9+10+11+12	90-107	
		Bounce 1,2,3,4,5,6,7,8,9,10,11,12	108-125	
		Bounce 12,11,10,9,8,7,6,5,4,3,2,1	126-143	
		Bounce 6+7,5+8,4+9,3+10,2+11,1+12	144-161	
		Fade 6+7,5+8,4+9,3+10,2+11,1+12	162-179	
		Snap 6+7,5+8,4+9,3+10,2+11,1+12	180-197	
		Bounce 1+12,2+11,3+10,4+9,5+8,6+7	198-215	
		Snap 1+2+3+4+9+10+11+12 then 5+6+7+8	216-233	
Fade Random	234-244			
Snap Random	245-255			
12	Macro Speed	Macro Speed	0-255	0
13	White Strobe	No Function	0-1	0
		Strobe (slow to fast)	2-127	
		Strobe Pulse (slow to fast)	128-170	
		Random Strobe All (slow to fast)	171-213	
14	White Dim Curve	Random 1-12 Strobe (slow to fast)	214-255	0
		No Function	0-50	
		Linear	51-100	
		Square Law	101-150	
		Slow Burn Out (slow to fast)	151-255	

Tiltbot Trio 23 Ch Mode

DMX Channel	Function	Description	Value	Init
1	Tilt	Tilt	0-255	127
2	Tilt Fine	Tilt Fine	0-255	127
3	White Dimmer	Dimmer (off to full)	0-255	0
4	White Duration	Duration	0-255	255
5	White Strobe	Strobe (slow to fast)	0-255	255
6	Macro	No Function	0-36	0
		Ramp Up	37-40	
		Ramp Up Random	41-44	
		Ramp Down	45-48	
		Ramp Down Random	49-52	
		Ramp Up Down	53-56	
		Ramp Up Down Random	57-60	
		Random White Beam	61-64	
		Random Single Pixel White	65-68	
		Lighting	69-72	
		Spikes (flash over light)	73-76	
		White Beam (left to right)	77-80	
		White Beam (left to right random)	81-84	
		White Beam (right to left)	85-88	
		White Beam (right to left random)	89-92	
		White Beam (left to right bounce)	93-96	
		White Beam (left to right random)	97-100	
		White Beam (left to right bounce)	101-104	
		White Beam (right to left bounce random)	105-108	
		Zig (6 steps)	109-112	
		Zig (6 steps random)	113-116	
		Zig (6 steps out to center pixel)	117-120	
		Zig (6steps out to center pixel random)	121-124	
		Zigzag (10 steps)	125-128	
		Zigzag (10 steps random)	129-132	
		Reserved	133-179	
		Double Flash	180-183	
		Double Flash (random)	184-187	
		Double Flash (beam color)	188-191	
		Double Flash (beam color random)	192-195	
		Double Flash (color beam)	196-199	
		Double Flash (color beam random)	200-203	
		Triple Flash	204-207	
		Triple Flash (random)	208-211	
		Triple Flash (bcb)	212-215	
		Triple Flash (bcb random)	216-219	
		Triple Flash (cbc)	220-223	
		Triple Flash (cbc random)	224-227	
		Quad Flash	228-231	
		Quad Flash (random)	232-235	
Quad Flash (bcb)	236-239			
Quad Flash (bcb random)	240-243			
Quad Flash (cbc)	244-247			
Quad Flash (cbc random)	248-251			
Reserved	252-255			

7	Control	No Function	0-49	0
		FX / Pattern Color Priority On	50-54	
		FX / Pattern Color Priority Off	55-59	
		No Function	60-69	
		Normal Tilt Control	70-74	
		Invert Tilt Control	75-79	
		Normal Pixel Orientation	80-84	
		Invert Pixel Orientation	85-89	
		No Function	90-209	
		Duration Percentage Mode On	210-214	
		Duration Percentage Mode Off	215-219	
		No Function	220-229	
		FX / Plate Color Priority On	230-234	
		FX / Plate Color Priority Off	235-239	
		No Function	240-247	
		Reset	248-255	
		8	Color Intensity	
9	Color Duration	7-650 Ms	0-255	255
10	Color Strobe	Strobe (slow to fast)	0-255	255
11	Color Macro	No Function	0-36	0
		Ramp Up	37-40	
		Ramp Up (random)	41-44	
		Ramp Down	45-48	
		Ramp Down (random)	49-52	
		Ramp Up / Down	53-56	
		Ramp Up / Down (random)	57-60	
		Random White Beam	61-64	
		Single White (random)	65-68	
		Lighting	69-72	
		Spikes (flash over low)	73-76	
		Reserved	77-179	
		Double Flash	180-191	
		Double Flash (random)	192-203	
		Triple Flash	204-215	
		Triple Flash (random)	216-227	
		Quad Flash	228-239	
Quad Flash (random)	240-251			
No Function	252-255			
12	LED Color	Red Intensity	0-255	255
13	LED Color	Green Intensity	0-255	255
14	LED Color	Blue Intensity	0-255	255
15	FX Cross Fade	FX Cross Fade Duration	0-255	0
16	Color FX	Movement (slow to fast)	0-255	0
17	Color Select	Color Pattern Select	0-255	0
18	White FX	Movement (slow to fast)	0-255	0
19	White Select	White Pattern Select	0-255	0
20	Color Back	Background Color Intensity	0-255	0
21	Background Color	Red Background Intensity	0-255	255
22	Background Color	Green Background Intensity	0-255	255
23	Background Color	Blue Background Intensity	0-255	255

Tiltbot Trio 50 Ch Mode

DMX Channel	Function	Description	Value	Init
1	Tilt	Tilt	0-255	127
2	Tilt Fine	Tilt Fine	0-255	127
3	LED Color	1 Red LED Intensity	0-255	255
4	LED Color	1 Green LED Intensity	0-255	255
5	LED Color	1 Blue LED Intensity	0-255	255
6	LED Color	2 Red LED Intensity	0-255	255
7	LED Color	2 Green LED Intensity	0-255	255
8	LED Color	2 Blue LED Intensity	0-255	255
9	LED Color	3 Red LED Intensity	0-255	255
10	LED Color	3 Green LED Intensity	0-255	255
11	LED Color	3 Blue LED Intensity	0-255	255
12	LED Color	4 Red LED Intensity	0-255	255
13	LED Color	4 Green LED Intensity	0-255	255
14	LED Color	4 Blue LED Intensity	0-255	255
15	LED Color	5 Red LED Intensity	0-255	255
16	LED Color	5 Green LED Intensity	0-255	255
17	LED Color	5 Blue LED Intensity	0-255	255
18	LED Color	6 Red LED Intensity	0-255	255
19	LED Color	6 Green LED Intensity	0-255	255
20	LED Color	6 Blue LED Intensity	0-255	255
21	LED Color	7 Red LED Intensity	0-255	255
22	LED Color	7 Green LED Intensity	0-255	255
23	LED Color	7 Blue LED Intensity	0-255	255
24	LED Color	8 Red LED Intensity	0-255	255
25	LED Color	8 Green LED Intensity	0-255	255
26	LED Color	8 Blue LED Intensity	0-255	255
27	LED Color	9 Red LED Intensity	0-255	255
28	LED Color	9 Green LED Intensity	0-255	255
29	LED Color	9 Blue LED Intensity	0-255	255
30	LED Color	10 Red LED Intensity	0-255	255
31	LED Color	10 Green LED Intensity	0-255	255
32	LED Color	10 Blue LED Intensity	0-255	255
33	LED Color	11 Red LED Intensity	0-255	255
34	LED Color	11 Green LED Intensity	0-255	255
35	LED Color	11 Blue LED Intensity	0-255	255
36	LED Color	12 Red LED Intensity	0-255	255
37	LED Color	12 Green LED Intensity	0-255	255
38	LED Color	12 Blue LED Intensity	0-255	255
39	LED Color	1 White LED Intensity	0-255	255
40	LED Color	2 White LED Intensity	0-255	255
41	LED Color	3 White LED Intensity	0-255	255
42	LED Color	4 White LED Intensity	0-255	255
43	LED Color	5 White LED Intensity	0-255	255
44	LED Color	6 White LED Intensity	0-255	255
45	LED Color	7 White LED Intensity	0-255	255
46	LED Color	8 White LED Intensity	0-255	255
47	LED Color	9 White LED Intensity	0-255	255
48	LED Color	10 White LED Intensity	0-255	255
49	LED Color	11 White LED Intensity	0-255	255
50	LED Color	12 White LED Intensity	0-255	255

Tiltbot Trio 62 Ch Mode

DMX Channel	Function	Description	Value	Init
1	Tilt	Tilt	0-255	127
2	Tilt Fine	Tilt Fine	0-255	127
3	Dimmer	Dimmer (off to full)	0-255	255
4	LED Color	Red LED Intensity	0-255	255
5	LED Color	Green LED Intensity	0-255	255
6	LED Color	Blue LED Intensity	0-255	255
7	RGB Macro (Select Color)	No Function	0-1	0
		Fade 1,2,3,4,5,6,12,11,10,9,8,7	2-17	
		Fade 12,11,10,9,8,7,1,2,3,4,5,6	18-35	
		Snap 1,2,3,4,5,6,12,11,10,9,8,7	36-53	
		Snap 12,11,10,9,8,7,1,2,3,4,5,6	54-71	
		Fade 1+2+3+4+5+6 then 7+8+9+10+11+12	72-89	
		Snap 1+2+3+4+5+6 then 7+8+9+10+11+12	90-107	
		Bounce 1+7,2+8,3+9,4+10,5+11,6+12	108-125	
		Bounce 6+12, 5+11,4+10,3+9,2+8,1+7	126-143	
		Fade 1+7,2+8,3+9,4+10,5+11,6+12	144-161	
		Fade 3+4+9+10, 2+8+5+11,1+7+6+12	162-179	
		Snap 1+12,2+11,3+10,4+9,5+8,6+7	180-197	
		Bounce 1+12,2+11,3+10,4+9,5+8,6+7	198-215	
		Snap 3+10, 4+9, 2+11, 5+8,1+12, 6+7	216-233	
Fade Random	234-244			
Snap Random	245-255			
8	Macro Speed	Macro Speed	0-255	0
9	RGB Strobe	No Function	0-1	0
		Strobe (slow to fast)	2-127	
		Strobe Pulse (slow to fast)	128-170	
		Random Strobe All (slow to fast)	171-213	
10	LED Color	Random 1-12 Strobe (slow to fast)	214-255	255
		White LED Intensity	0-255	
11	White Macro (Select Intensity)	No Function	0-1	0
		Fade 1,2,3,4,5,6,7,8,9,10,11,12	2-17	
		Fade 12,11,10,9,8,7,6,5,4,3,2,1	18-35	
		Snap 1,2,3,4,5,6,7,8,9,10,11,12	36-53	
		Snap 12,11,10,9,8,7,6,5,4,3,2,1	54-71	
		Fade 1+2+3+4+5+6 then 7+8+9+10+11+12	72-89	
		Snap 1+2+3+4+5+6 then 7+8+9+10+11+12	90-107	
		Bounce 1,2,3,4,5,6,7,8,9,10,11,12	108-125	
		Bounce 12,11,10,9,8,7,6,5,4,3,2,1	126-143	
		Bounce 6+7,5+8,4+9,3+10,2+11,1+12	144-161	
		Fade 6+7,5+8,4+9,3+10,2+11,1+12	162-179	
		Snap 6+7,5+8,4+9,3+10,2+11,1+12	180-197	
		Bounce 1+12,2+11,3+10,4+9,5+8,6+7	198-215	
		Snap 1+2+3+4+9+10+11+12 then 5+6+7+8	216-233	
Fade Random	234-244			
Snap Random	245-255			
12	Macro Speed	Macro Speed	0-255	0
13	White Strobe	No Function	0-1	0
		Strobe (slow to fast)	2-127	
		Strobe Pulse (slow to fast)	128-170	
		Random Strobe All (slow to fast)	171-213	
14	White Dim Curve	Random 1-12 Strobe (slow to fast)	214-255	0
		No Function	0-50	
		Linear	51-100	
		Square Law	101-150	
		Slow Burn Out (slow to fast)	151-255	

15	LED Color	1 Red LED Intensity	0-255	0
16	LED Color	1 Green LED Intensity	0-255	0
17	LED Color	1 Blue LED Intensity	0-255	0
18	LED Color	2 Red LED Intensity	0-255	0
19	LED Color	2 Green LED Intensity	0-255	0
20	LED Color	2 Blue LED Intensity	0-255	0
21	LED Color	3 Red LED Intensity	0-255	0
22	LED Color	3 Green LED Intensity	0-255	0
23	LED Color	3 Blue LED Intensity	0-255	0
24	LED Color	4 Red LED Intensity	0-255	0
25	LED Color	4 Green LED Intensity	0-255	0
26	LED Color	4 Blue LED Intensity	0-255	0
27	LED Color	5 Red LED Intensity	0-255	0
28	LED Color	5 Green LED Intensity	0-255	0
29	LED Color	5 Blue LED Intensity	0-255	0
30	LED Color	6 Red LED Intensity	0-255	0
31	LED Color	6 Green LED Intensity	0-255	0
32	LED Color	6 Blue LED Intensity	0-255	0
33	LED Color	7 Red LED Intensity	0-255	0
34	LED Color	7 Green LED Intensity	0-255	0
35	LED Color	7 Blue LED Intensity	0-255	0
36	LED Color	8 Red LED Intensity	0-255	0
37	LED Color	8 Green LED Intensity	0-255	0
38	LED Color	8 Blue LED Intensity	0-255	0
39	LED Color	9 Red LED Intensity	0-255	0
40	LED Color	9 Green LED Intensity	0-255	0
41	LED Color	9 Blue LED Intensity	0-255	0
42	LED Color	10 Red LED Intensity	0-255	0
43	LED Color	10 Green LED Intensity	0-255	0
44	LED Color	10 Blue LED Intensity	0-255	0
45	LED Color	11 Red LED Intensity	0-255	0
46	LED Color	11 Green LED Intensity	0-255	0
47	LED Color	11 Blue LED Intensity	0-255	0
48	LED Color	12 Red LED Intensity	0-255	0
49	LED Color	12 Green LED Intensity	0-255	0
50	LED Color	12 Blue LED Intensity	0-255	0
51	LED Color	1 White LED Intensity	0-255	0
52	LED Color	2 White LED Intensity	0-255	0
53	LED Color	3 White LED Intensity	0-255	0
54	LED Color	4 White LED Intensity	0-255	0
55	LED Color	5 White LED Intensity	0-255	0
56	LED Color	6 White LED Intensity	0-255	0
57	LED Color	7 White LED Intensity	0-255	0
58	LED Color	8 White LED Intensity	0-255	0
59	LED Color	9 White LED Intensity	0-255	0
60	LED Color	10 White LED Intensity	0-255	0
61	LED Color	11 White LED Intensity	0-255	0
62	LED Color	12 White LED Intensity	0-255	0

Item List

Tiltbot Trio

Part Number	Description
1310PCBLEDMOD	COMPLETE LED MODULE
1310PCBDRIA	LED DRIVER A
1310PCBDRIB	LED DRIVER B
1310PCBDISMAI	MAIN PCB AND DISPLAY
1310PCBPOW	POWER RELAY PCB
1310FAN	FAN
1310POW	POWER SUPPLY
1310LEDRGB	SINGLE RGB LED
1310LEDWHI	SINGLE WHITE LED
1310HOUSTI	OVERLAY STICKER
1310HOUYOK	HOUSING YOKE
1310HOUFAN	METAL FAN HOUSING HOLDER
1310BEZARM	PLASTIC ARM BEZEL
1310BEZFAN	PLASTIC FAN COVER BEZEL
1310GLAFRO	FRONT COVER GLASS
1310HOUGUI1	TILT YOKE ARM LOCATION RING
1310HOUMOT	TILT MOTOR GEAR
1310CONPOW	SEETRONIC POWER IN&OUT PANEL CON
1310CONSIG5	SEETRONIC SIGNAL IN&OUT 5PIN PANEL CON
1310CONSIG3	SEETRONIC SIGNAL IN&OUT 3PIN PANEL CON
1310MOTTIL	TILT MOTOR
1310SEAFRO	FRONT GLASS FRONT WEATHER SEAL
1310SEABACK	FRONT GLASS BACK WEATHER SEAL
1310SEADIS	DISPLAY WEATHER SEAL

Rigging the fixture

Caution!

1. The installations must be carried out by an authorized dealer or trained professional.
2. Unit may cause severe injuries if you have doubts concerning the safety do not install.
3. Unit is to be 24 inches away from flammable materials (decoration material)
4. Use high quality installation equipment to hang unit.

When rigging a unit it is very important that you follow common safety procedures. Rigging requires extensive experience including but not limited to calculating working loads, material being used and periodic safety inspections. If you lack these qualifications, do not attempt the installation yourself, instead use a professional structural rigger.

When rigging the unit always be secured with a secondary safety attachment. The installation location of the projector has got to be built in the way that it can hold 10 times the weight for 1 hour with out any harming. Installation should be checked at least one time a year by a skilled person.

When mounting the fixture must be mounted in a way water will not sit on the panel power or signal connections.

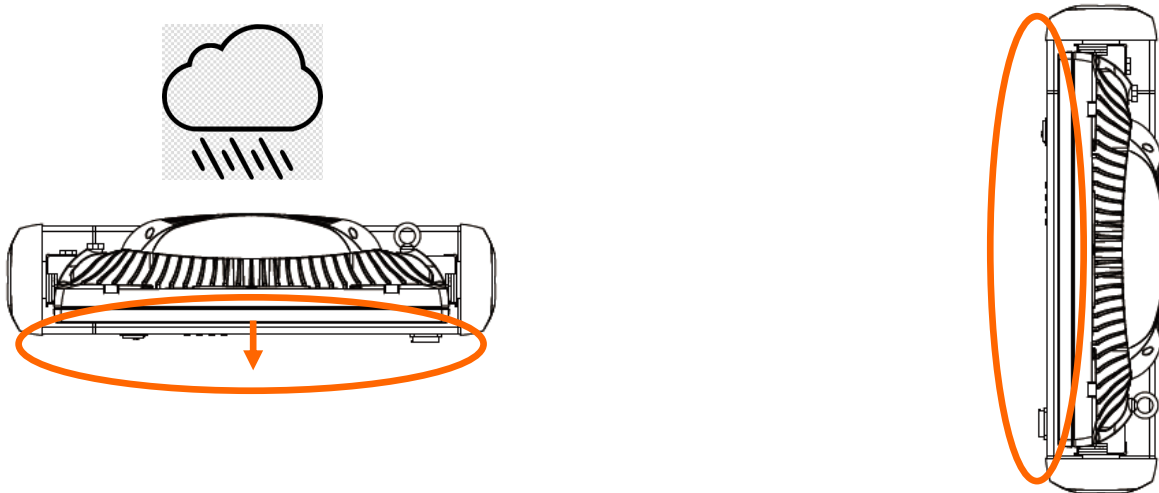

Cleaning and Maintenance

Installation Maintenance: The operator has to make sure that the unit is operating safely and has the installations and electronics checked by an expert every 2 years.

The following points have to be considered during the inspection:

- 1) All screws used for installing the device or part of the device have to be tightly connected and must not be corroded.
- 2) There must not be any deformations on the housing, fixation and installation spots (ceiling, suspension, trussing).
- 3) The electronic power supply cables must not show any damages, material fatigue (e.g. porous cables) or sediments.
Further instructions depending on the installation spot and usage have to be adhered by a skilled installer and any safety problems have to be removed.

Note: There is no serviceable parts inside the device except for the LED's. Maintenance and service operations are to be carried out by authorized dealers.

Replacing the fuse: When possible only replace the fuse with the same type and rating.

Replacing the power cable: If the power cable of this device becomes damaged, it has to be replaced by authorized dealers or trained professional only.

Should you have further questions , please contact your dealer.

Warranty Information

Warranty Conditions

- Unless otherwise stated in writing, your product is covered by a one year parts and labor limited warranty.
- LED's and LAMPS are not guaranteed to match in color temperature or output.
- It is the owner's responsibility to furnish receipts or invoices for verification of purchase, date, and reseller or distributor. If purchase date cannot be provided, date of manufacture will be used to determine warranty period.
- Goods returned under warranty must follow the proper authorization procedure and must be accompanied by a copy of the original invoice.
- Goods repaired under warranty will be returned to the owner with the freight prepaid by MSI via the most economical means of shipment.
- Repair or replacement as provided for under this warranty is the exclusive remedy of the consumer. MEGA SYSTEMS INC. makes no warranties, express or implied, with respect to any product, and Mega Systems specifically disclaims any warranty of merchantability or fitness for a particular purpose. Mega Systems shall not be liable for any indirect, incidental or consequential damage, including lost profit, sustained or incurred in connection with any product or caused by product defect or the partial or total failure of any product regardless of the form of action, weather in contract, tort (including negligence), strict liability or otherwise, and weather or not such damage was foreseen or unforeseen.
- Warranty is void if the product is misused, damaged, modified in any way, or for unauthorized repairs or parts. This warranty gives you specific legal rights, and you may also have other rights which vary from state to state.

Customer Support

Mega Lite has a customer support line to provide set up help and to answer any question should you encounter a problem. Please visit our website for any other related technical documents. For service related issue please contact our service dept.

Monday—Friday 9am to 6pm CST
Voice: 210-684-2600
E-mail: service@megasystemsinc.com

Manual Version

Please Visit www.mega.lighting for the most up to date manual version

Document Version	Date	Fixture Software	Notes
1.1	03/28/2020	V1.1	



Mega-Lite
18668 Highway 16N
Helotes, Texas 78023
Ph 210-684-2600 Fax 210-855-6279
www.mega.lighting / info@mega.lighting